

Product discontinued  
[See datasheet](#)

**NOVOHALL**  
**Rotary Sensor**  
**touchless technology**  
**transmissive**

Series RFC-4800

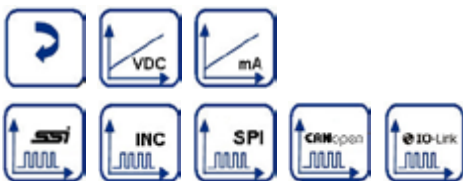
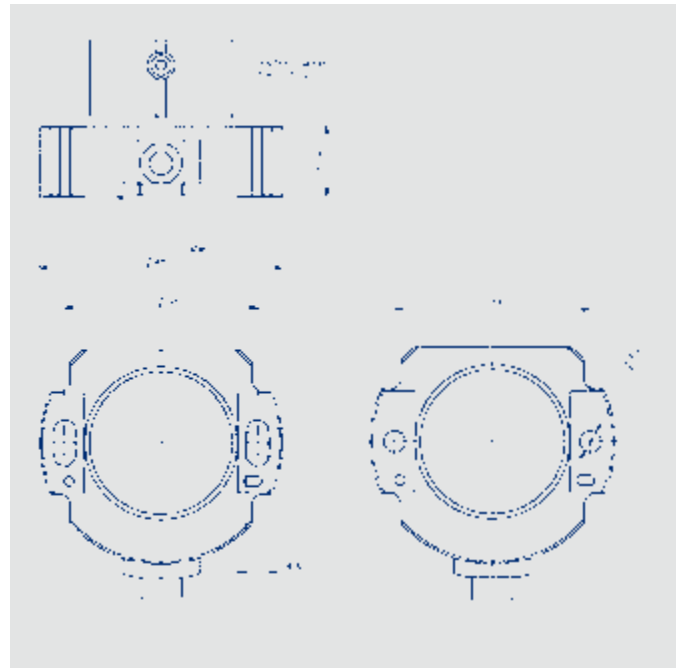

**Special features**

- Touchless hall technology
- Electrical range up to 360°
- 2-part, mechanically decoupled
- High protection class, IP67, IP6K9K
- Resolution up to 14 bit
- Wear-free
- Temperature range -40 °C to +125 °C
- Single and multi-channel versions
- Optimized for use in industrial and mobile applications
- Interfaces:
  - Voltage, current, SSI, incremental, CANopen, SPI, IO-Link
- Customized versions

The two-part design consisting of sensor and magnetic position marker offers great flexibility when mounting. The absence of shaft and bearing makes the assembly much less sensitive to axial and radial application tolerances - separate couplings are obsolete.

Measurements can be made transmissively through any non-ferromagnetic material.

The sensor is perfectly suitable for use in harsh environmental conditions through the completely encapsulated electronics.

**Applications**

- Manufacturing Engineering
  - Textile machinery
  - Packaging machinery
  - Sheet metal and wire machinery
- Automation technology
- Medical engineering
- Mobile working machines
  - Industrial trucks
  - Construction machinery
  - Agricultural and forestry machinery
- Marine applications

## Contents

<b>Drawings</b>	3
<b>Mechanical Data</b>	4
<b>Output Characteristics</b>	5
<hr/>	
<b>Analog Versions for Industrial Applications</b>	
Technical Data	6
Ordering Specifications	7
<b>Analog Versions for Mobile Applications</b>	
Technical Data	8
Ordering Specifications	9
<hr/>	
<b>Digital Versions</b>	
SSI	10
Incremental for Industrial an Mobile Applications	11
SPI	14
Ordering Specifications	15
<b>Fieldbus Versions, IO-Link</b>	
CANopen	16
IO-Link	17
Ordering Specifications	18
<hr/>	
<b>Accessories</b>	
Position Markers	19
M12 Connector System	23
Signal processing	26
<hr/>	
<b>Customized Versions</b>	
Connecting Options	27

Drawings

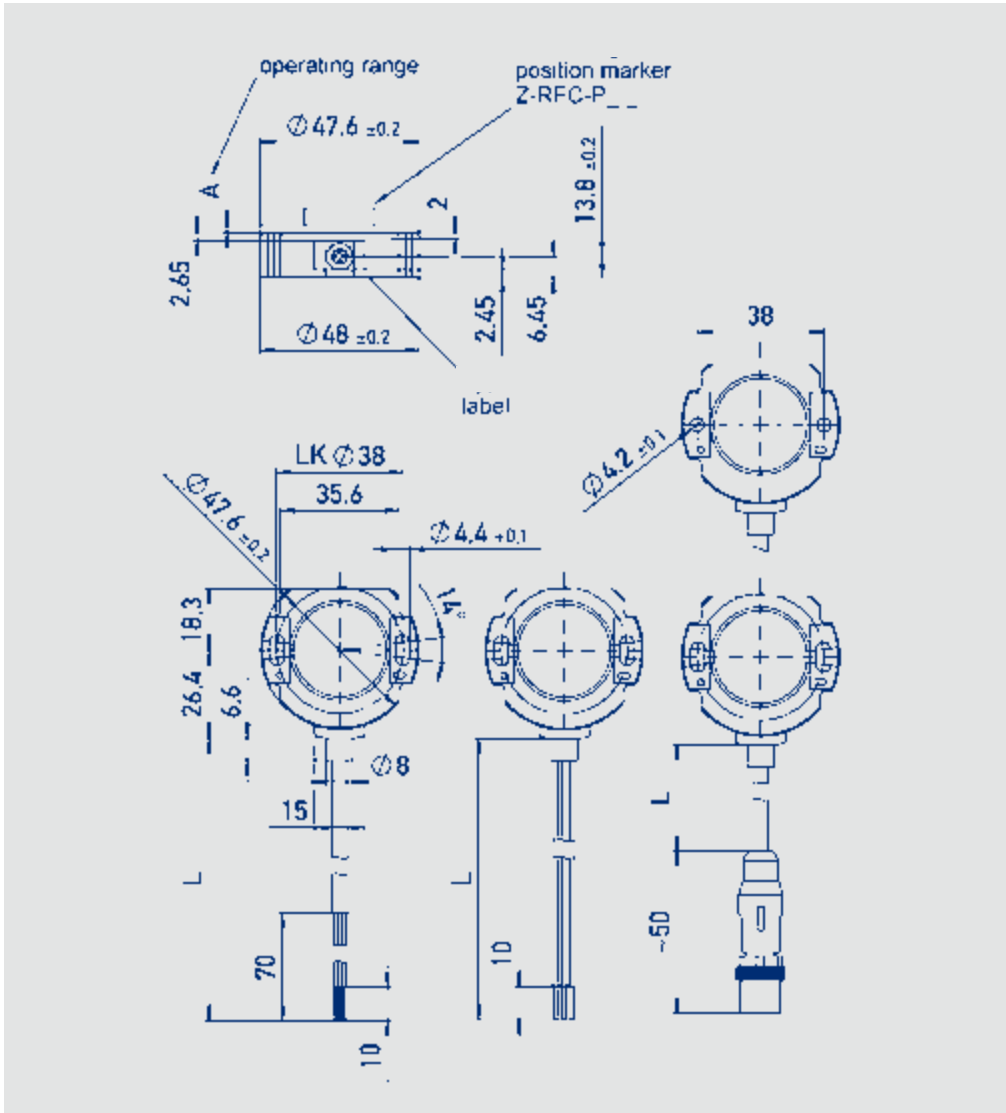

CAD data see  
[www.novotechnik.de/en/download/cad-data/](http://www.novotechnik.de/en/download/cad-data/)

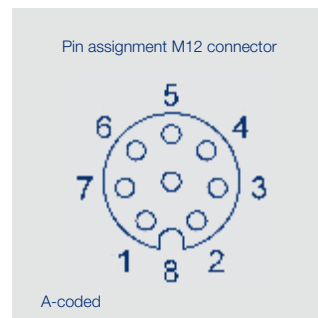
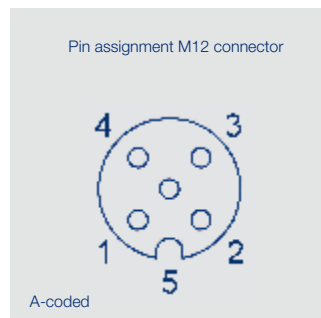
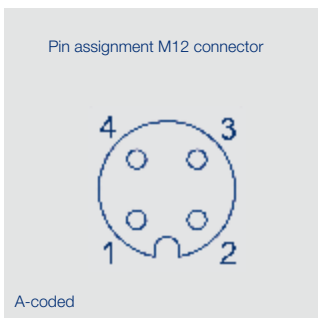

## Mechanical Data

<b>Description</b>		
Housing	high grade, temperature resistant plastic	
Electrical connection	Cable 4x 0.14 mm <sup>2</sup> , AWG 26, TPE, shielded (analog voltage / current CE) Cable 4x 0.14 mm <sup>2</sup> , AWG 26, TPE, unshielded (analog voltage / current mobile) Cable 4x 0.5 mm <sup>2</sup> , AWG 20, TPE, shielded (CANopen) Cable 5x 0.14 mm <sup>2</sup> , AWG 26, PUR, shielded (SPI) Cable 8x 0.25 mm <sup>2</sup> , AWG 24, TPE, shielded (SSI, Incremental, CANopen IN/OUT) Wire 0.5 mm <sup>2</sup> , AWG 20, PVC (analog voltage / current mobile, Incremental Open Collector) Connector M12x1, 4-pin / 5-pin / 8-pin with cable L=0.15 m	
<b>Mechanical Data</b>		
Dimensions	see dimension drawing	
Mounting	with 2 lens flange head screws M4 (enclosed in delivery)	
Fastening torque of mounting screws	250	Ncm
Mechanical travel	360 continuous	°
Maximum operational speed	mechanically unlimited	
Weight (without connection)	approx. 50	g
Vibration IEC 60068-2-6	5 ... 2000 A <sub>max</sub> = 0.75 a <sub>max</sub> = 20	Hz mm g
Shock IEC 60068-2-27	50 (6 ms)	g
Life	mechanically unlimited	
Protection class DIN EN 60529	IP67 / IP68 / IP6K9K (M12 connector: IP67)	

**Output Characteristics**

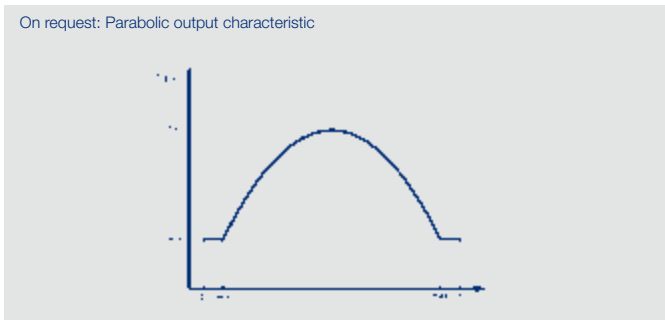
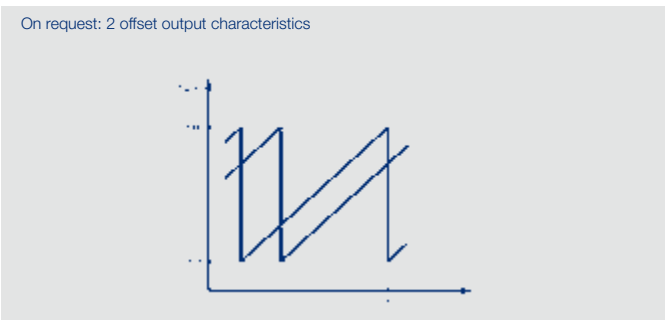
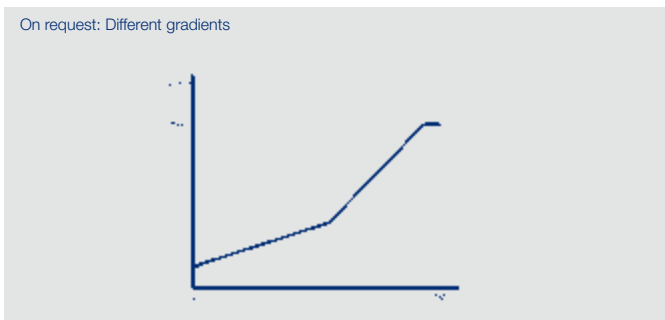
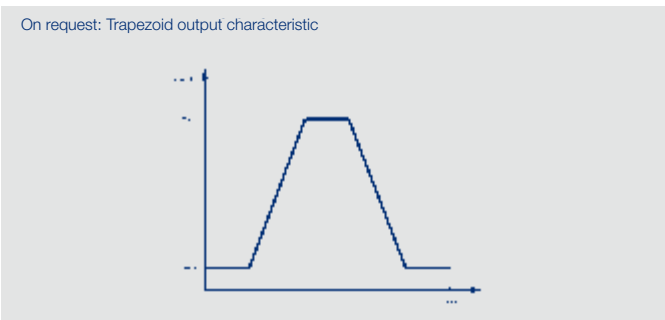
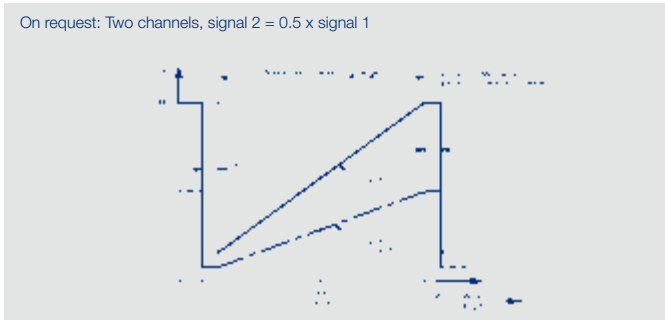
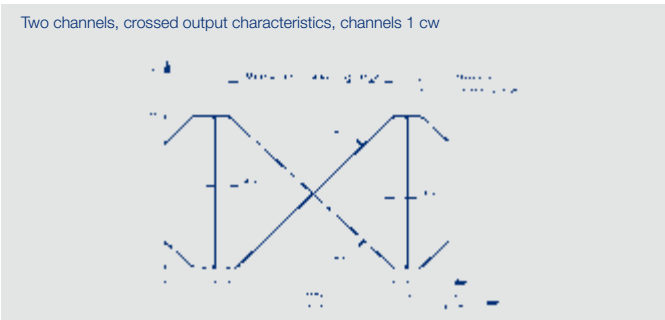
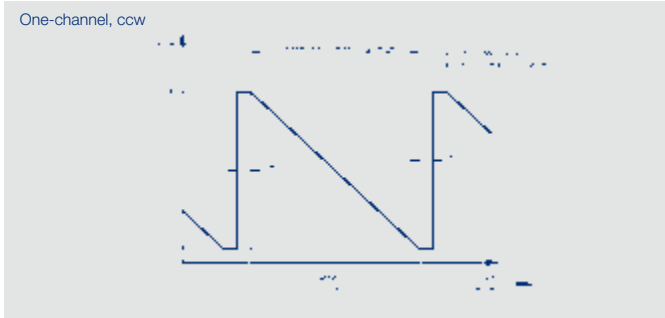
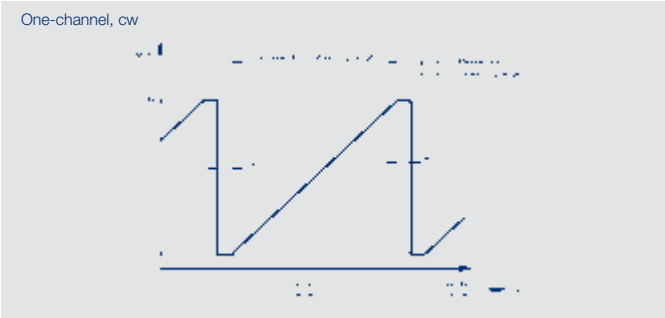

**Technical Data -  
Analog Versions  
- Voltage  
- Current**  
for Industrial Applications

**Technical Data - Versions for Industrial Applications**

Design optimized for use in machine and plant engineering. High reliability, simple interface to PLC, high variety.

Type Designations	RFC-4801-____-2__-____ ratiometric	RFC-4801-____-11__-____ voltage	RFC-4801-____-12__-____ current	
<b>Electrical Data</b>				
Output signal	ratiometric to supply voltage 0.25 ... 4.75 V 0.5 ... 4.5 V (load ≥1 kΩ)	0.1 ... 10 V (load ≥10 kΩ)	4 ... 20 mA (burden max. 500 Ω)	
Number of channels	1 / 2	1	1	
Update rate	typical 5			kHz
Resolution	12			bit
Measuring range	0 ... 30 up to 0 ... 360, in 10°-steps			°
Independent linearity	≤ 0.5			±% FS
Repeatability	≤ 0.1			°
Hysteresis	≤ 0.1			°
Temperature error at measuring range 30 up to 170°	±0,825	±1,24	±1,24	% FS
Temperature error at measuring range 180 up to 360°	±0,41	±0,66	±0,66	% FS
Supply voltage Ub	5 (4,5 ... 5,5)	24 (18 ... 30)	24 (18 ... 30)	VDC
Current consumption (w/o load)	typical 15 (typical 8 on request) per channel			mA
Reverse voltage	yes, supply lines and outputs			
Short circuit protection	yes (vs. GND and supply voltage)			
Insulation resistance (500 VDC)	≥ 10			MΩ
Cross-section cable	AWG 26, 0.14			mm²
<b>Environmental Data</b>				
Operating temperature	-40 ... +125 -25 ... +85 with M12 connector	-40 ... +125 -25 ... +85 with M12 connector	-40 ... +105 (+125, if supply voltage ≤ 28 V) -25 ... +85 with M12 connector	°C °C
MTTF (DIN EN ISO 13849-1 parts count method, w/o load, wc)	290 (one-channel) 288 (per channel, partly redundant)	98 (one-channel)	111 (one-channel)	years years
Functional safety	If you need assistance in using our products in safety-related systems, please contact us			
EMC compatibility	EN 61000-4-2 Electrostatic discharge (ESD) 4 kV, 8 kV EN 61000-4-3 Electromagnetic fields 10 V/m EN 61000-4-4 Electrical fast transients (burst) 1 kV EN 61000-4-6 Conducted disturbances, induced by RF-fields 10 V eff. EN 61000-4-8 Power frequency magnetic fields 3 A/m EN 55011/EN 55022/A1 Radiated disturbances class B			

**Connection assignment**

**One-channel versions**

Signal	Cable code 2 __	Connector M12 code 501
Supply voltage Ub	GN	pin 1
Signal output	WH	pin 2
GND	BN	pin 3
Not assigned	YE	pin 4

Cable shielding connect to GND.

**Redundant versions**

Signal	Cable code 2 __	Connector M12 code 501
Supply voltage Ub	GN	pin 1
Signal output 1	WH	pin 2
GND	BN	pin 3
Signal output 2	YE	pin 4

Cable shielding connect to GND.



When the marking of the position marker is pointing towards the cable, the sensor output is near the electrical center position.

**Ordering Specifications - Analog Versions - Voltage - Current for Industrial Applications**

**Ordering specifications**

**Preferred types printed in bold:**

- Delivery time up to 25 pcs. within 10 working days EXW
- Best low-volume pricing

**Supply voltage Ub**

- 1: 24 V (18 ... 30 V)**
- 2: 5 V (4.5 ... 5.5 V)**

**Output signal supply voltage Ub = 24 V**

- 1: 0.1 ... 10 V (only one-channel)**
- 2: 4 ... 20 mA (only one-channel)**

**Output signal supply voltage Ub = 5 V**

- 1: 0.25 ... 4.75 V ratiometric to supply voltage Ub**
- 2: 0.5 ... 4.5 V ratiometric to supply voltage Ub**

**Output characteristics**

- 1: Rising cw**
  - 2: Rising ccw**
  - 3: Crossed output channel 1 rising cw (partly redundant)**
- Other output characteristics on request

**Electrical connections**

- 201: Cable 4-pole, 0,5 m shielded**
  - 202: Cable 4-pole, 1 m shielded**
  - 206: Cable 4-pole, 3 m shielded**
  - 210: Cable 4-pole, 5 m shielded
  - 220: Cable 4-pole, 10 m shielded
  - 501: M12 connector 4-pin, with cable, L = 0.15 m, shielded**
- Cable versions and assembled connectors on request

**R F C - 4 8 0 1 - 6 3 6 - 2 1 1 - 2 0 2**

Series

**Mechanical version**

- 4801: Elongated hole mounting for easy adjustment**
- 4802: Round hole mounting

**Measuring range**

- 03: Angle 0° ... 30° min.
- ...
- 06, 12, 18, 24, 36**
- ...
- 36: Angle 0° ... 360° max.
- Other angles on request

**Number of channels**

- 6: Single output 1 x supply voltage Ub / 1 x output**
- 7: partly redundant 1 x supply voltage Ub / 2 x output (only at supply voltage Ub = 5 V)**

## Technical Data - Analog Versions - Voltage - Current for Mobile Applications

<b>Technical Data - Versions for Mobile Applications</b>			
These versions are optimized for the high requirements in mobile applications. Tested to the highest requirements as ISO-pulses and high interferences to ISO 11452.			
Type Designations	RFC-4801- ___-2___-___ ratiometric	RFC-4801- ___-3___-___ voltage	RFC-4801- ___-32___-___ current
<b>Electrical Data</b>			
Output signal	ratiometric to supply voltage Ub 0.25 ... 4.75 V 0.5 ... 4.5 V (load $\geq 1$ k $\Omega$ )	0.25 ... 4.75 V 0.5 ... 4.5 V (load $\geq 10$ k $\Omega$ )	4 ... 20 mA (burden max. 250 $\Omega$ )
Number of channels	1 / 2	1 / 2	1
Update rate	typical 5		kHz
Resolution	12		bit
Measuring range	0 ... 30 up to 0 ... 360, in 10°-steps		°
Independent linearity	$\leq 0,5$		$\pm\%$ FS
Repeatability	$\leq 0,1$		°
Hysteresis	$\leq 0,1$		°
Temperature error at measuring range 30 and 170°	$\pm 0.825$	$\pm 1.24$	% FS
Temperature error at measuring range 180 and 360°	$\pm 0.41$	$\pm 0.66$	% FS
Supply voltage Ub	5 (4.5 ... 5.5)	12/24 (9 ... 34)	12/24 (9 ... 34)
Current consumption (w/o load)	typical 15 (typical 8 on request) per channel		mA
Reverse voltage	yes, supply lines and outputs		
Short circuit protection	yes (vs. GND and supply voltage)		
Insulation resistance (500 VDC)	$\geq 10$		M $\Omega$
Cross-section cable	AWG 26, 0.14		mm <sup>2</sup>
Cross-section wire	AWG 20, 0.5		mm <sup>2</sup>
<b>Environmental Data</b>			
Operating temperature	-40 ... +125 -25 ... +85 with connector M12	-40 ... +125 -25 ... +85 with connector M12	-40 ... +105 (+125, if supply voltage $\leq 28$ V) -25 ... +85 with connector M12
MTTF (DIN EN ISO 13849-1 parts count method, w/o load, wc)	290 (one-channel) 288 (per channel, partly redundant) 290 (per channel, fully redundant)	91 (one-channel) 101 (per channel, partly redundant)	109 (one-channel) years years years
Functional safety	If you need assistance in using our products in safety-related systems, please contact us		
EMC compatibility	ISO 11452-2 Radiated EM RF fields 100 V/m ISO 11452-4 BCI (Bulk current injection) 100 mA CISPR25 Radiated emission class 5 SAE J1113-2 Conducted immunity level 2 SAE J1113-13 Packaging and handling 4-20 kV SAE J1113-22 Radiated magnetic field 80 $\mu$ T SAE J1113-26 AC power line electric field 15 kV EN61000-4-2 Immunity to static discharge (ESD) 4 kV, 8 kV, 15 kV EN 55011/EN 55022/A1 Radiated disturbances class B		

### Connection assignment

<b>One-channel versions</b>			
Signal	Lead wires code 4 __	Cable code 2 __	Connector M12 code 551
Supply voltage Ub	RD	GN	pin 1
Signal output	BU	WH	pin 2
GND	BK	BN	pin 3
Not assigned	-	YE	pin 4

<b>Redundant versions</b>			
Signal	Lead wires code 4 __	Cable code 2 __	Connector M12 code 551
Supply voltage Ub 1	RD	GN	pin 1
Signal output 1	BU	WH	pin 2
GND 1	BIK	BN	pin 3
Signal output 2	BU/WH	YE	pin 4
Supply voltage Ub 2	RD/WH	-	-
GND 2	BK/WH	-	-



When the marking of the position marker is pointing towards the cable, the sensor output is near the electrical center position.



## Ordering Specifications - Analog Versions for Mobile Applications

### Ordering specifications

**Preferred types printed in bold:**

- Delivery time up to 25 pcs. within 10 working days EXW
- Best low-volume pricing

**Supply voltage**

- 2: Supply voltage  $U_b = 5\text{ V}$  (4.5 ... 5.5 V)  
3: Supply voltage  $U_b = 12/24\text{ V}$  (9.0 ... 34.0 V)

**Output signal Supply voltage  $U_b = 5\text{ V}$**

- 1: 0.25 ... 4.75 V ratiometric to supply voltage  $U_b$   
2: 0.5 ... 4.5 V ratiometric to supply voltage  $U_b$

**Output signal supply voltage  $U_b = 12/24\text{ V}$**

- 2: 4 ... 20 mA (only one-channel)  
4: 0.5 ... 4.5 V  
5: 0.25 ... 4.75 V

**Output characteristics**

- 1: Rising cw  
2: Rising ccw  
3: Crossed output channel 1 rising cw (partly redundant)  
4: Crossed output channel 1 rising cw (fully redundant)  
Other output characteristics on request

**Electrical connections**

- 251: Cable 4-pole, 0,5 m unshielded, one-channel and partly redundant  
252: Cable 4-pole, 1 m unshielded, one-channel and partly redundant  
256: Cable 4-pole, 3 m unshielded, one-channel and partly redundant  
260: Cable 4-pole, 5 m unshielded, one-channel and partly redundant  
270: Cable 4-pole, 10 m unshielded, one-channel and partly redundant  
401: Lead wires 3 x L = 0,5 m, single  
411: Lead wires 4 x L = 0,5 m, partly redundant  
421: Lead wires 6 x L = 0,5 m, fully redundant  
551: M12 connector 4-pin, with cable L = 0.15 m unshielded, one-channel and partly redundant  
Cable versions and assembled connectors on request

**R F C - 4 8 0 1 - 6 3 6 - 2 1 1 - 2 5 2**

Series

**Mechanical version**

- 4801: Elongated hole mounting for easy adjustment  
4802: Round hole mounting

**Measuring range**

- 03: Angle 0° ... 30° min.  
...  
**06, 12, 18, 24, 36**  
...  
36: Angle 0° ... 360° max.  
Other angles on request

**Number of channels**

- 6: one-channel 1x supply voltage  $U_b$  / 1 x output  
7: partly redundant 1 x supply voltage  $U_b$  / 2 x output  
8: fully redundant 2 x supply voltage  $U_b$  / 2 x output (only at supply voltage  $U_b = 5\text{ V}$ )

## Technical Data SSI Interface

Type Designations	RFC-48_--214-41 _ - _ - _ Supply voltage 5 VDC	RFC-48_--214 - 44 _ - _ - _ Supply voltage 24 VDC
<b>Electrical Data</b>		
Protocol	SSI 13 bit (12 bit data + 1 stop bit)	
Inputs	RS422 compatible, CLK lines via optocoupler galvanically isolated	
Monoflop time (tm)	16	µs
Coding	Gray	
Update rate (internal)	2 000	kHz
Resolution across 360°	12	bit
Measuring range	360	°
Maximum operational speed position marker	30 000, higher speeds on request	min-1
Independent linearity	typical 0,5	±% FS
Repeatability	≤ 0.2	°
Hysteresis	≤ 0.7, lower hysteresis on request	°
Temperature error	0.375	±% FS
Supply voltage Ub	5 (4.5 ... 5.5)	24 (18 ... 30)
Current consumption (w/o load)	typical 27	typical 10
Reverse voltage	yes, supply lines	
Short circuit protection	yes (ouput vs. supply voltage and GND)	yes (output vs. GND)
Ohmic load at outputs	≥ 120	Ω
Max. clock rate	1	MHz
Insulation resistance (500 VDC)	≥ 10	MΩ
Cross-section cable	AWG 24, 0.25	mm²
<b>Environmental Data</b>		
Operating temperature	-40 ... +85 (-25 ... +85 with M12 connector)	
MTTF (DIN EN ISO 13849-1 parts count method, w/o load, wc)	141	102
Functional safety	If you need assistance in using our products in safety-related systems, please contact us	
EMC compatibility	EN 61000-4-2 Electrostatic discharge (ESD) 4 kV, 8 kV EN 61000-4-3 Electromagnetic fields 10 V/m EN 61000-4-4 Electrical fast transients (burst) 1 kV EN 61000-4-6 Conducted disturbances, induced by RF fields 10 V eff. EN 61000-4-8 Power frequency magnetic fields 30 A/m EN 55016-2-3 Noise radiation class B	

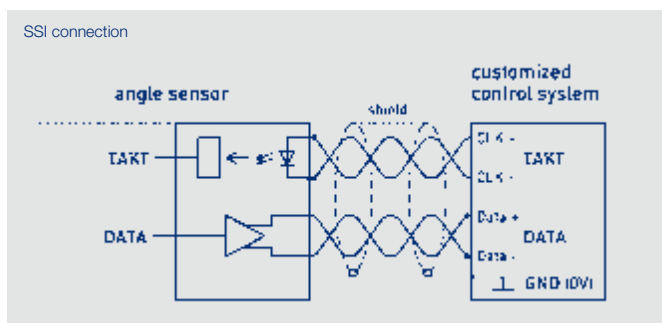
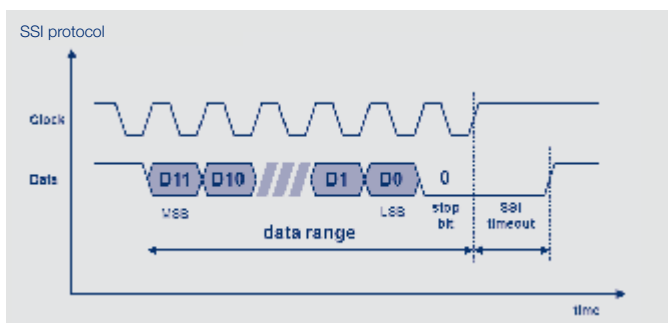

### Connection assignment

Signal	Cable code 4 _ _	Connector M12 code 531
Supply voltage Ub	WH	pin 1
GND	BN	pin 2
Clock input SSI Clk-	GN	pin 3
Clock input SSI Clk+	YE	pin 4
Signal output SSI Data-	GY	pin 5
Signal output SSI Data+	PK	pin 6
Not assigned	BU	pin 7
Not assigned	RD	pin 8



When the marking of the position marker is pointing towards the cable, the sensor output is near the electrical center position.

## Technical Data Incremental Interface for Industrial Applications

Type Designations	RFC-48__-2__-5__-__-__ Supply voltage 5 VDC	RFC-48__-2__-530-__-__ Supply voltage 24 VDC, TTL	RFC-48__-2__-534-__-__ Supply voltage 24 VDC, HTL	
<b>Electrical Data</b>				
Outputs	A+ / A- B+ / B- Z+ / Z-			
Level	RS-422, TTL-compatible	RS-422, TTL-compatible	HTL-compatible, Push-Pull	
Length Z-pulse	90 electrical, between 2 edges A / B			°
Pulses per revolution	1024, other resolutions see page 12			ppr
Counts per revolution (after quadrature)	4096			
Option Low Speed				
- Minimum edge separation	8			µs
- Minimum input frequency of counter input	32			kHz
- Maximum operational speed	1 800			min <sup>-1</sup>
Option High Speed				
- Minimum edge separation	0.5			µs
- Minimum input frequency of counter input	500			kHz
- Maximum operational speed	29 000, higher speeds on request			min <sup>-1</sup>
Measuring range	360			°
Independent linearity	typical 0.5			±% FS
Repeatability	≤ 0.2			°
Hysteresis	≤ 0.7, lower hysteresis on request			°
Temperature error	0.375			±% FS
Supply voltage Ub	5 (4.5 ... 5.5)	24 (18 ... 30)	24 (18 ... 30)	VDC
Current consumption (w/o load)	typical 20	typical 10	typical 10	mA
Reverse voltage	yes, supply lines			
Short circuit protection	yes, all outputs vs. GND and supply voltage	yes, all outputs vs. GND	yes, all outputs vs. GND and supply voltage	
Ohmic load at output	≥ 120 per channel A / B / Z	≥ 120 per channel A / B / Z	≥ 750 per channel A / B / Z	Ω
Insulation resistance (500 VDC)	≥ 10			MΩ
Cross-section cable	AWG 24, 0.25			mm <sup>2</sup>
<b>Environmental Data</b>				
Operating temperature	-40 ... +85 (-25 ... +85 with M12 connector)			°C
MTTF (DIN EN ISO 13849-1 parts count method, w/o load, wc)	183	122	122	years
Functional safety	If you need assistance in using our products in safety-related systems, please contact us			
EMC compatibility	EN 61000-4-2 Electrostatic discharge (ESD) 4 kV, 8 kV EN 61000-4-3 Electromagnetic fields 10 V/m EN 61000-4-4 Electrical fast transients (burst) 1 kV EN 61000-4-6 Conducted disturbances, induced by RF fields 10 V eff. EN 61000-4-8 Power frequency magnetic fields 30 A/m EN 55016-2-3 Radiated disturbances			

### Connection assignment

Signal	Cable code 4 __	Connector M12 code 531
Supply voltage Ub	WH	pin 1
GND	BN	pin 2
A-	GN	pin 3
A+	YE	pin 4
B-	GY	pin 5
B+	PK	pin 6
Z+	BU	pin 7
Z-	RD	pin 8

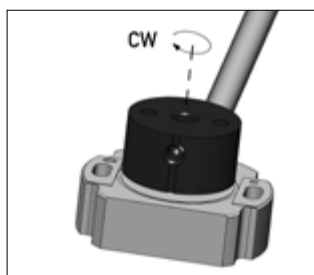

When the marking of the position marker is pointing away from the cable, the output is in the vicinity of the reference pulse (Z).  
Rotational direction CW:  
A leads before B.

## Technical Data Incremental Interface

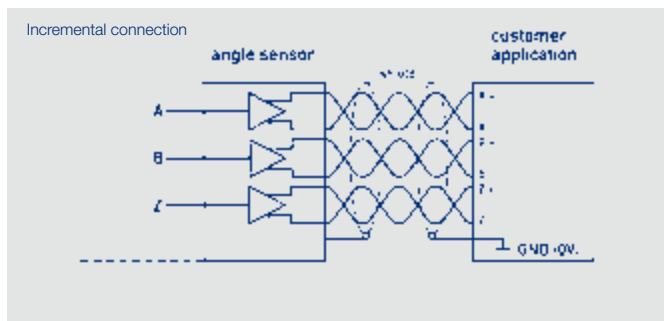
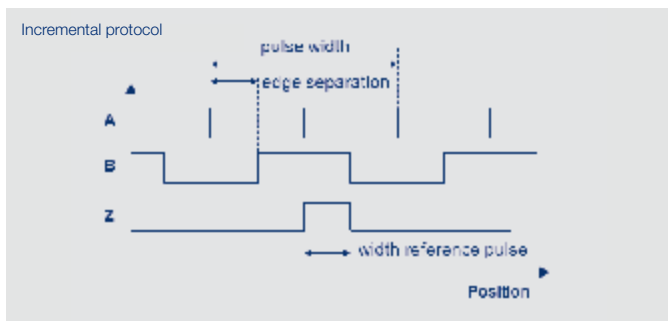

### Electrical Data

Pulses per revolution	1024	512	256	128	ppr
Counts per revolution (after quadrature)	4096	2048	1024	512	
Option Low Speed					
- Minimal edge separation	8				µs
- Minimum input frequency of counter input	32	32	32*	32*	kHz
- Maximum operational speed	1800	3600	7200	14400	min <sup>-1</sup>
Option High Speed					
- Minimal edge separation	0,5				µs
- Minimum input frequency of counter input	500	500	500*	105*	kHz
- Maximum operational speed	29000, higher speeds on request				

\*) The requirement for the minimum input frequency of counter input is reduced at lower speed (see below charts).

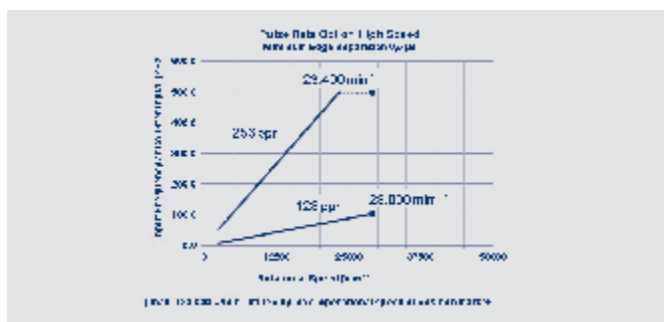
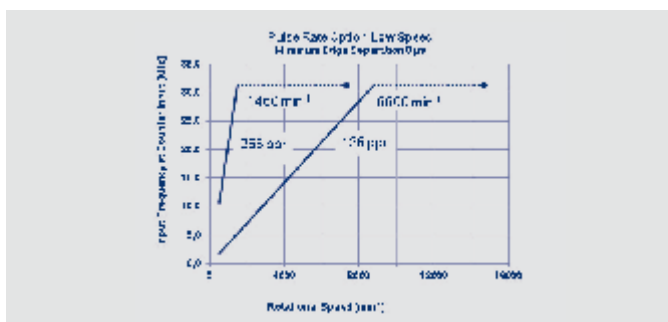

## Technical Data Incremental Interface for Mobile Applications

Type Designations	RFC-48_ -2_ -556- - - -				
	Supply voltage 12/24 VDC, open collector				
<b>Electrical Data</b>					
Outputs	A- B-				
Level	Open collector				
Pulses per revolution	1024	512	256	128	ppr
Counts per revolution (after quadrature)	4096	2048	1024	512	
Minimum edge separation	8				µs
Minimum input frequency of counter input	32	32	32*	32*	kHz
Maximum operational speed	580	3500	7200	14400	min <sup>-1</sup>
Measuring range	360				°
Independent linearity	typical 0.5				±% FS
Repeatability	≤ 0.2				°
Hysteresis	≤ 0.7, lower hysteresis on request				
Temperature error	0.375				±% FS
Supply voltage Ub	12/24 (9 ... 34)				VDC
Current consumption (w/o load)	typical 10				mA
Overvoltage protection	60 (temporary / 10 min.)				VDC
Reverse voltage	yes, supply lines				
Short circuit protection	yes, all outputs vs. GND and supply voltage Ub				
Load outputs vs. supply voltage Ub	20 per channel				mA
Insulation resistance (500 VDC)	≥ 10				MΩ
Cross-section cable / lead wires	AWG 20, 0.5				mm <sup>2</sup>
<b>Environmental Data</b>					
Operating temperature	-40 ... +85				°C
MTTF (DIN EN ISO 13849-1 parts count method, w/o load, wc)	83				years
Functional safety	If you need assistance in using our products in safety-related systems, please contact us				
EMC compatibility	ISO TR 10605 Packaging and Handling + Component Test 8 kV, 15 kV ISO 11452-2 Radiated EM RF fields, absorber hall 100 V/m ISO 11452-5 Radiated EM RF fields, stripline 200 V/m ISO 7637-2 Pulse 1 Level 3, 2a, 2b, 3a, 3b, 4, 5 Level 4 CISPR 25 Radiated emission class 5				

\*) The requirements for the minimum input frequencies of counter input is reduced at lower speed (see page 12).

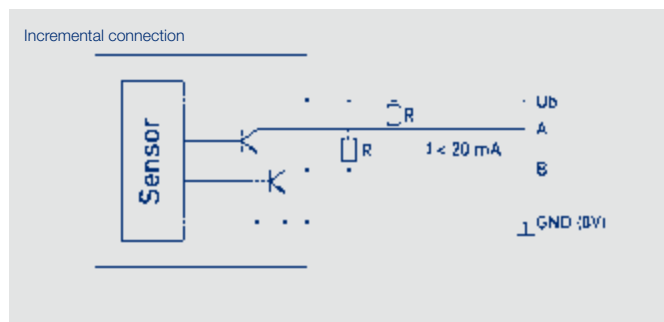
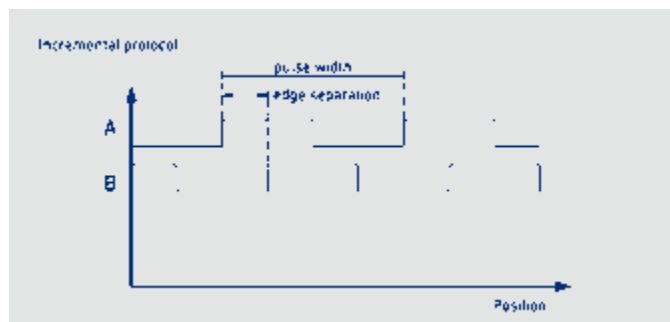

Connection assignment			
Signal	Lead wires code 4 _ _	Cable code 2 _ _	Connector M12 code 551
A-	BU	GN	pin 1
Supply voltage Ub	RD	WH	pin 2
GND	BK	BN	pin 3
B-	BU/WH	YE	pin 4

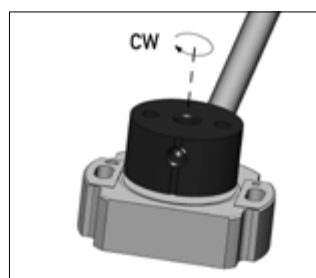

Rotational direction CW:  
A leads before B

## Technical Data SPI Interface

<b>Type Designations</b>	<b>RFC-48_-2_-8_-_-_-</b> <b>Supply voltage 5 VDC</b>	
<b>Electrical Data</b>		
Protocol	SPI	
Coding	Binary code	
Level SCLK, MOSI, /SS	TTL level (s. application note SPI protocol)	
Update rate internal	5	kHz
Resolution across 360°	14	bit
Measuring range	360	°
Independent linearity	≤ 0.5	±% FS
Repeatability	≤ 0.1	°
Hysteresis	≤ 0.1	°
Temperature error	±0.625	% FS
Supply voltage Ub	5 (4.5 ... 5.5)	VDC
Current consumption (w/o load)	typical 15	mA
Reverse voltage	yes, supply lines	
Short circuit protection	yes (vs. GND and supply voltage)	
Max. clock rate	400	kHz
Insulation resistance (500 VDC)	≥ 10	MΩ
Cross-section cable	AWG 26, 0.14	mm²
<b>Environmental Data</b>		
Operating temperature	-40 ... +85	°C
MTTF (DIN EN ISO 13849-1 parts count method, w/o load, wc)	272	years
Functional safety	If you need assistance in using our products in safety-related systems, please contact us	
EMC compatibility	EN 61000-4-2 electrostatic discharge (ESD) 4 kV, 8 kV EN 61000-4-3 electromagnetic fields 10 V/m EN 61000-4-4 electrical fast transients (Burst) 1 kV EN 61000-4-6 conducted disturbances, induced by RF fields 10 V eff. EN 61000-4-8 Power frequency magnetic fields 30 A/m EN 55011/EN 55022/A1 Radiated disturbances class B	

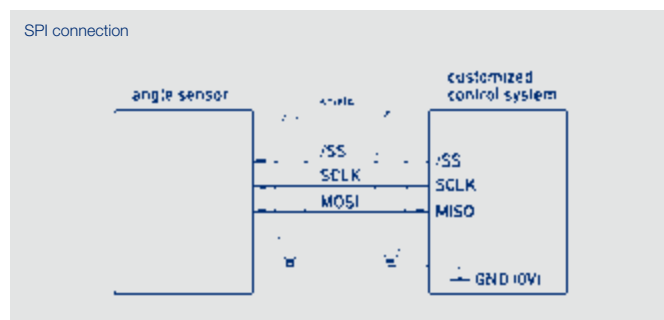
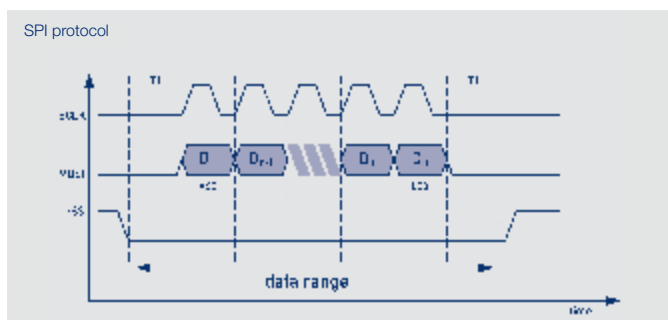

### Connection assignment

Signal	Cable code 302
Supply voltage Ub	GN
GND	BN
MOSI / MISO	YE
SCLK	GY
/SS (slave select)	WH



When the marking of the position marker is pointing towards the cable, the sensor output is near the electrical center position.

**Ordering Specifications - Digital Versions - SSI - Incremental - SPI**

**Ordering specifications**

**Preferred types printed in bold:**

- Delivery time up to 25 pcs. within 10 working days EXW
- Best low-volume pricing

**Supply voltage Ub / Interface**

**4: Synchronous-Serial Interface (SSI)**

**5: Incremental Inrface A / B / Z**

**8: Serial Peripheral Interface (SPI)**

**Interface parameters for SSI Interface**

**11: 5 V (4.5 ... 5.5 V) Supply voltage, output RS422 comp., Gray code, rising cw**

12: 5 V (4.5 ... 5.5 V) Supply voltage, output RS422 comp., Gray code rising ccw

**41: 24 V (18 ... 30 V) Supply voltage, output RS422 comp., Gray code, rising cw**

42: 24 V (18 ... 30 V) Supply voltage, output RS422 comp., Gray code rising ccw

**Interface parameters for Incremental Interface**

**Low Speed Mode (minimum edge separation 8 µs)**

**15: 5V (4.5 ... 5.5 V) supply voltage, output RS422, TTL-compatible**

**35: 24V (18 ... 30 V) supply voltage, output RS422, TTL-compatible**

**39: 24V (18 ... 30 V) supply voltage, output HTL-compatible, Push-Pull**

**56: 12/24V (9 ... 34 V) supply voltage, output low side, open collector**

**High Speed Mode (minimal edge separation 0,5 µs)**

10: 5 V (4.5 ... 5.5 V) supply voltage, output RS422, TTL-compatible

30: 24 V (18 ... 30 V) supply voltage, output RS422, TTL-compatible

34: 24 V (18 ... 30 V) supply voltage, output HTL-compatible, Push-Pull

UWV signals instead of ABZ signals for motor commutation on request

Absolute position at Power On (Power on Burst) on request

**Interface parameters for SPI Interface**

**31: 5 V (4.5 ... 5.5 V) Supply voltage, Binary code, rising cw**

**Electrical connections**

**SSI / Incremental:**

**432: Cable 8-pole, 1.0 m, shielded**

**436: Cable 8-pole, 3.0 m, shielded**

440: Cable 8-pole, 5.0 m, shielded

450: Cable 8-pole, 10.0 m, shielded

**531: Connector M12x1 8-pole with cable, L = 0.15 m, shielded**

**Incremental Open Collector:**

**252: Cable 4-pole, 1 m, unshielded**

**256: Cable 4-pole, 3 m, unshielded**

260: Cable 4-pole, 5 m, unshielded

270: Cable 4-pole, 10 m, unshielded

**411: Lead wires 4 x L = 0.5 m**

**551: Connector M12x1 4-pin with cable, L = 0.15 m, unshielded**

**SPI**

**302: Cable 5-pole 1.0 m, shielded**

Cable versions and assembled connectors on request

**R F C - 4 8 0 2 - 2 1 2 - 4 4 1 - 4 3 2**

Series

**Resolution SSI Interface**

**12: 12 bit**

Other resolutions on request

**Resolution Incremental Interface**

**12: 1024 ppr - 4096 counts (after quadrature)**

11: 512 ppr - 2048 counts (after quadrature)

10: 256 ppr - 1024 counts (after quadrature)

09: 128 ppr - 512 counts (after quadrature)

Other resolutions on request

**Resolution SPI Interface**

**14: 14 bit**

**Interface**

**2: Digital Interface**

**Mechanical version**

4801: Elongated hole

**4802: Round hole mounting**

## Technical Data



<b>Type Designations</b>	<b>RFC-48 _ _ - 214 - 6 _ _ - _ _ _</b> <b>CANopen</b>	
<b>Electrical Data</b>		
Measured variables	Position and speed	
Measuring range	360	°
Measurement range speed	0 ... 1600	min-1
Number of channels	1 / 2 see ordering specifications	
Output signal / protocol	CANopen protocol to CiA DS-301 V4.2.0, Device profile DS-406 V3.2 Encoder Class C2, LSS services to CiA DS-305 V1.1.2	
Programmable parameter	Position, speed, cams, working areas, rotating direction, scale, offset, node-ID, baud rate	
Node-ID	1 ... 127 (default 127)	
Baud rate	50 ... 1000 see ordering specifications	kBaud
Resolution across 360° (position)	14	bit
Resolution speed	$360/2^{14} \approx 0,022$	°/ms
Update rate	1	kHz
Independent linearity	$\leq 0.5$	±% FS
Repeatability	$\leq 0.36$	°
Hysteresis	$\leq 0.36$	°
Temperature error	0.2	±% FS
Supply voltage Ub	12/24 (8 ... 34)	VDC
Current consumption (w/o load)	< 100	mA
Reverse voltage	yes, supply lines	
Short circuit protection	yes, output vs.GND and supply voltage Ub (up to 40 VDC)	
Overvoltage protection	< 45 (permanent)	VDC
Insulation resistance (500 VDC)	$\geq 10$	MΩ
Cross-section cable	AWG 20, 0.5	
Bus termination internal	120, optionally, see ordering specifications	Ω
<b>Environmental Data</b>		
Operation temperature	-40 ... +105 (-25 ... +85 with M12 connector)	
MTTF (DIN EN ISO 13849-1 parts count method, w/o load, wc)	one-channel: 71 / two-channel: 58	years
Functional safety	If you need assistance in using our products in safety-related systems, please contact us	
EMC compatibility	ISO TR 10605 Packaging and Handling + Component Test 8 kV ISO 11452-2 Radiated EM RF fields, Absorberhall 100 V/m ISO 11452-5 Radiated EM RF fields, Stripline 200 V/m CISPR 25 Radiated emission class 3 ISO 7637-2 Pulse 1, 2a, 2b, 3a, 3b, 4 (24 V systems), 5 Level 5 ISO 7637-3 Transient transmission Level 4	

### Connection assignment

Signal	Cable Code 2 _ _	Connector M12 Code 511
CAN_SHLD	Shield	pin 1
Supply voltage Ub	WH	pin 2
GND	BN	pin 3
CAN_H	YE	pin 4
CAN_L	GN	pin 5

Cable shielding connect to GND.

Signal	Cable Code 432
CAN_SHLD	Shield
Supply voltage Ub	WH and RD
GND	BN and BU
CAN_H IN	YE
CAN_L IN	GN
CAN_H OUT	PK
CAN_L OUT	GY



When the marking of the position marker is pointing towards the cable, the sensor output is near the electrical center position.



Technical Data

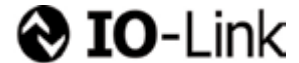

<b>Type Designations</b>	<b>RFC-48 _ _ - 214 - A _ _ - _ _ _</b> <b>IO-Link</b>	
<b>Electrical Data</b>		
Measured variables	Position (other process data such as speed, revolution counter or cams on request)	
Measuring range	360	°
Number of channels	1	
Output signal / protocol	IO-Link Spec V1.1 to IEC 61131-9, Smart Sensor Profile	
Programmable parameter	Zero point offset, averaging, rotating direction	
Resolution across 360° (Position)	14	bit
Update rate	1	kHz
Transfer rate	COM 3 (230.4 kB)	
Frame type	2.2	
Minimum cycle time	1	ms
Independent linearity	0.5	±% FS
Repeatability	0.36	°
Hysteresis	0.36	°
Temperature error	0.2	±% FS
Supply voltage Ub	24 (18 ... 30)	VDC
Current consumption (w/o load)	< 100	mA
Reverse voltage	yes, supply lines	
Short circuit protection	yes, output vs. GND and Ub (up to 40 VDC)	
Overvoltage protection	< 35 (permanent)	VDC
Insulation resistance (500 VDC)	≥ 10	MΩ
Cross-section cable	AWG 20, 0.5 (4 pole) or AWG 24, 0.25 (8 pole)	
<b>Environmental Data</b>		
Operation temperature	-40 ... +105 (-25 ... +85 with M12 connector)	°C
MTTF (DIN EN ISO 13849-1 parts count method, w/o load, wc)	single channel: 76	Jahre
Functional safety	If you need assistance in using our products in safety-related systems, please contact us	
EMC compatibility	EN 61000-4-2 Electrostatic discharge (ESD) 4 kV, 8 kV EN 61000-4-3 Electromagnetic fields 10 V/m EN 61000-4-4 Electrical fast transients (burst) 2 kV EN 61000-4-6 Conducted disturbances, induced by RF fields 10 V eff. EN 55016-2-3 Radiated disturbances	



**Connection assignment**

Signal	Cable code 2 _ _	Connector M12 code 551
Supply voltage Ub	BN	pin 1
Do not connect*	GN	pin 2
GND	WH	pin 3
C/Q	YE	pin 4

\*) Alternatively on GND



When the marking of the position marker is pointing towards the cable, the sensor output is near the electrical center position.

## Ordering Specifications



### Ordering specifications

**Preferred types printed in bold:**

- Delivery time up to 25 pcs. within 10 working days EXW
- Best low-volume pricing

#### Interface

6: CANopen Interface

A: IO-Link

#### Interface parameters CANopen 6 \_ \_

1: 1 x position, 1 x speed

2: 2 x position, 2 x speed

5: 1 x position, 1 x speed with bus termination 120 Ω

6: 2 x position, 2 x speed with bus termination 120 Ω

#### Interface parameters IO-Link A \_ \_

11: 1 x position, rising cw

Other process data such as speed, revolution counter or cams on request

#### Baud rate

1: Baud rate 1000 kBaud

2: Baud rate 800 kBaud

3: Baud rate 500 kBaud

4: Baud rate 250 kBaud

5: Baud rate 125 kBaud

7: Baud rate 50 kBaud

#### Electrical connections CANopen

202: Cable 4-pole 1.0 m, shielded

432: Cable 8-pole, 1.0 m shielded (CAN IN/OUT)

511: Connector M12x1, 5-pin, with cable, L= 0.15m, shielded

#### Electrical connections IO-Link

252: Cable 4-pole, 1.0 m, unshielded

256: Cable 4-pole, 3.0 m, unshielded

260: Cable 4-pole, 5.0 m, unshielded

270: Cable 4-pole, 10. m, unshielded

551: Connector M12x1, 4-pin, with cable, L= 0.15m, unshielded

Cable versions and assembled connectors on request

**R F C - 4 8 5 2 - 2 1 4 - 6 1 5 - 5 1 1**

Series

#### Mechanical version

4851: Elongated hole

4852: Round hole mounting

## Position Markers

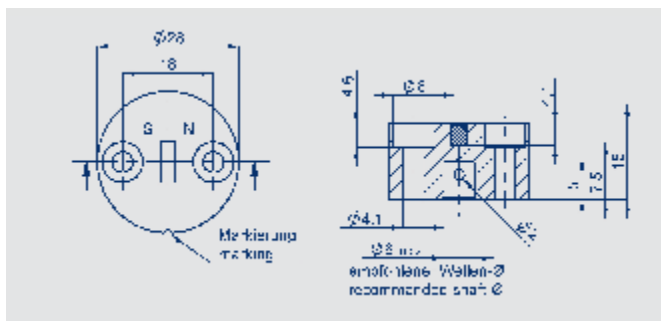

### Z-RFC-P01

Position marker for frontal fixation with 2 cylinder head screws M4x20 (with microencapsulation) or with locking pin (both are included in delivery).

**Not recommended for new designs.**

- max. permitted radial offset  $\pm 1.5$  mm
- packaging unit:  
1 pc. P/N 005660  
25 pcs. P/N 056079

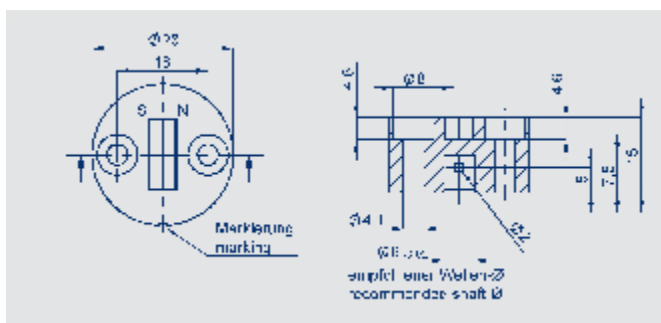

### Z-RFC-P02

Position marker for frontal fixation with 2 cylinder head screws M4x20 (with microencapsulation) or with locking pin (both are included in delivery).

- max. permitted radial offset  $\pm 3$  mm
- packaging unit:  
1 pc. P/N 005661  
25 pcs. P/N 056080

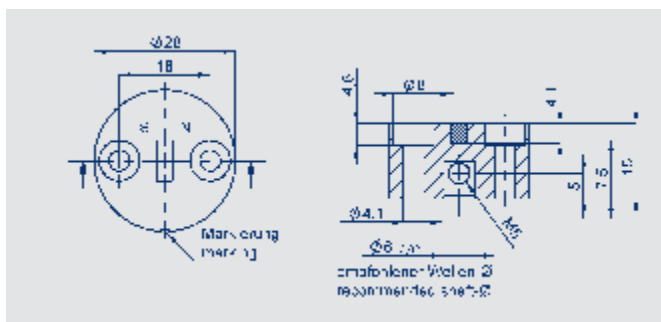

### Z-RFC-P07

Position marker for fixation with threaded pin M5 (included in delivery).

**Not recommended for new designs.**

- max. permitted radial offset  $\pm 1.5$  mm
- packaging unit:  
1 pc. P/N 056069  
25 pcs. P/N 056083

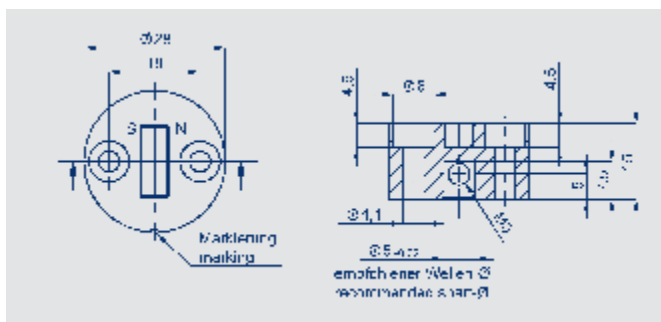

### Z-RFC-P08

Position marker for fixation with threaded pin pin M5 (included in delivery).

- max. permitted radial offset  $\pm 3$  mm
- packaging unit:  
1 pc. P/N 056070  
25 pcs. P/N 056084

## Position Markers

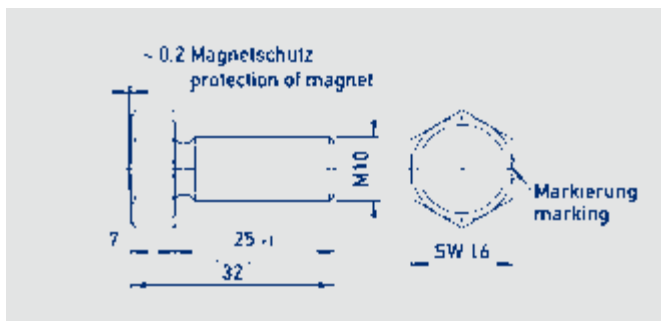

**Z-RFC-P18**  
Screw position marker  
M10 x 25 mm, similar DIN 933,  
Aluminum anodized,  
magnet potted

- max. permitted radial offset  $\pm 3$  mm
- packaging unit:  
1 pc. P/N 104756  
25 pcs. P/N 104757

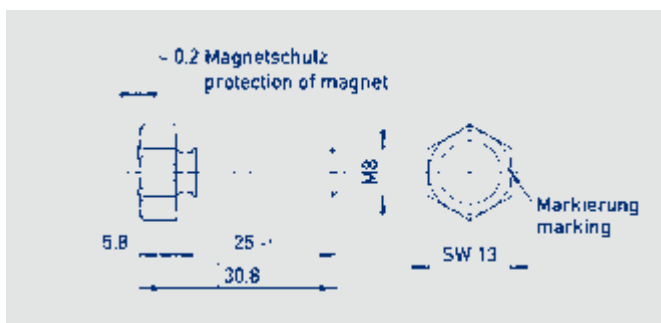

**Z-RFC-P19**  
Screw position marker  
M8 x 25 mm, similar DIN 933 /  
ISO 4017  
Aluminum anodized,  
magnet potted

- max. permitted radial offset  $\pm 1,5$  mm
- packaging unit:  
1 pc. P/N 104754  
25 pcs. P/N 104755

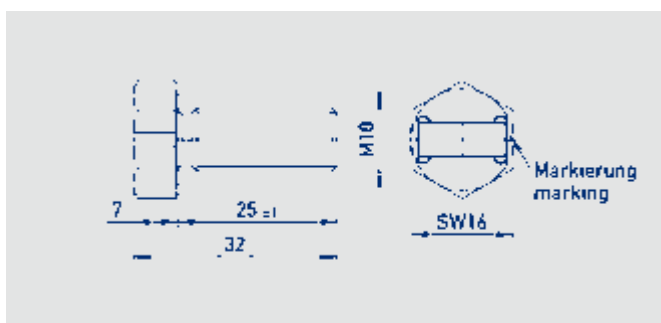

**Z-RFC-P20**  
Screw position marker  
M10 x 25 mm, similar DIN 933,  
Aluminum anodized

- max. permitted radial offset  $\pm 3$  mm
- packaging unit:  
1 pc. P/N 104758  
25 pcs. P/N 104759

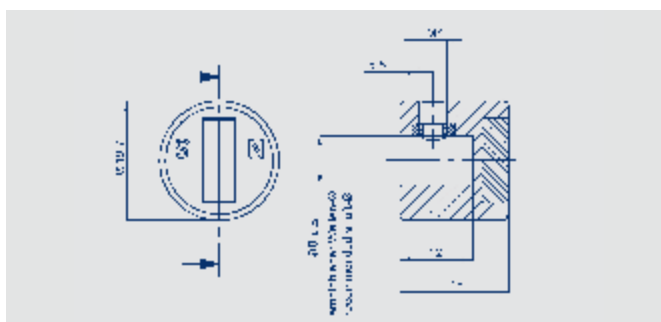

**Z-RFC-P23**  
Position marker for fixation with  
threaded pin M4  
(included in delivery)

- max. permitted radial offset  $\pm 3$  mm
- packaging unit:  
1 pc. P/N 056074  
25 pcs. P/N 056085

## Position Markers

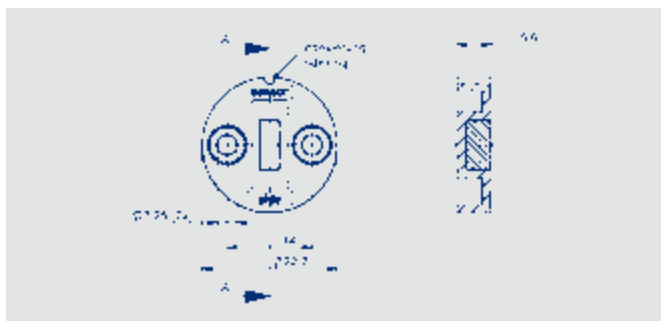

### Z-RFC-P30

Position marker for frontal fixation with 2 fillister screws M3x8 (included in delivery)

- max. permitted radial offset  $\pm 1.5$  mm
- packaging unit:  
1 pc. P/N 056086  
25 pcs. P/N 056087

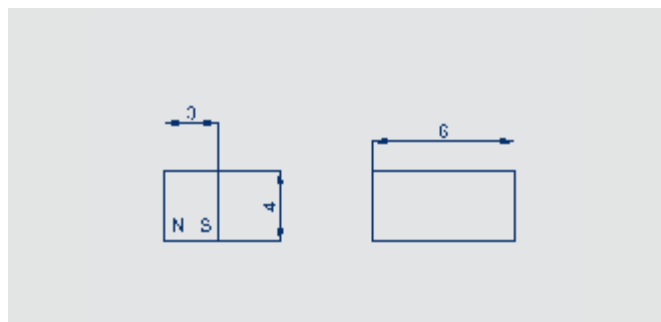

### Z-RFC-P03

Magnet for direct application onto customer's shaft

- max. permitted radial offset  $\pm 1,5$  mm
- packaging unit:  
1 pc. P/N 005658  
50 pcs. P/N 056081

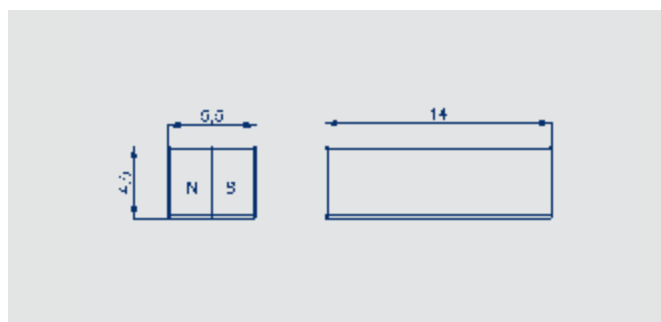

### Z-RFC-P04

Magnet for direct application onto customer's shaft

- max. permitted radial offset  $\pm 3$  mm
- packaging unit:  
1 pc. P/N 005659  
50 pcs. P/N 056082

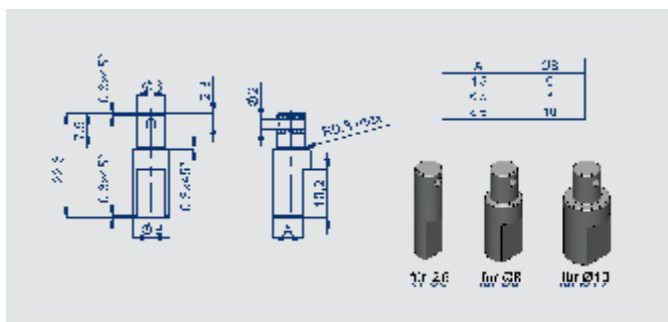

### Shaft adapter for

### Z-RFC-P01 and Z-RFC-P02

Fixation at position marker with locking pin

- Z-RFC-S01:  $\varnothing 6$  mm, P/N 056206
- Z-RFC-S02:  $\varnothing 8$  mm, P/N 056207
- Z-RFC-S03:  $\varnothing 10$  mm, P/N 056208

## Position Markers

### Working distances (mm)

Interface	Z-RFC- _ _ _											
	P01	P02	P03	P04	P07	P08	P18	P19	P20	P23	P30	
Analog / SPI single	0 ... 1.5	0 ... 4	0 ... 1.5	0 ... 4	0 ... 1.5	0 ... 4	0 ... 4.5	0 ... 2.2	0 ... 4	0 ... 4	0 ... 1.5	
Analog redundant	0 ... 1.5	0 ... 4	0 ... 1.5	0 ... 4	0 ... 1.5	0 ... 4	0 ... 4	0 ... 1.7	0 ... 4	0 ... 4	0 ... 1.5	
SSI / Incremental	-	0 ... 1.4	-	0 ... 1.4	-	0 ... 1.4	-	-	0 ... 1.4	0 ... 1.4	-	
CANopen / IO-Link single	0.7 ... 2.2	2.3 ... 5	0.7 ... 2.2	2.3 ... 5	0.7 ... 2.2	2.3 ... 5	0 ... 4.5	0 ... 2.2	2.3 ... 5	2.3 ... 5	0.7 ... 2.2	
CANopen redundant	0.3 ... 1.8	1.9 ... 4.5	0.3 ... 1.8	1.9 ... 4.5	0.3 ... 1.8	1.9 ... 4.5	0 ... 4	0 ... 1.7	1.9 ... 4.5	1.9 ... 4.5	0.3 ... 1.8	

### Mounting instructions Z-RFC-P03 / Z-RFC-P04

- In general, we recommend mounting on not magnetizable materials, otherwise the stated working distances can change
- If the shaft is magnetizable please keep sufficient distance
- When the magnet is mounted in the shaft, the shaft may not be magnetizable
- If the magnet is axially fixed on a magnetizable shaft the working distances reduces by approximately 20 %

### Lateral magnet offset

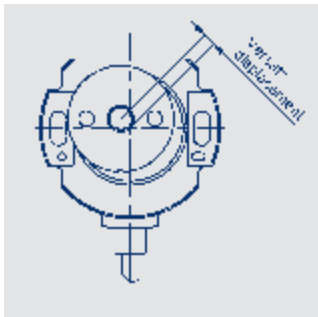

Lateral magnet offset will cause additional linearity error. The angle error, which is caused by radial displacement of sensor and position marker depends on the used position marker or magnet.

### Additional linearity error (°) at radial displacement

Interface	Z-RFC-P02 / P04 / P08 / P20 / P23			Z-RFC-P01 / P03 / P07 / P30			Z-RFC-P18			Z-RFC-P19		
	0.5 mm	1 mm	2 mm	0.5 mm	1 mm	2 mm	0.5 mm	1 mm	2 mm	0.5 mm	1 mm	2 mm
Analog / SPI / CANopen / IO-Link single	0.4	1.1	3.5	1.4	3.7	-	0.7	1.3	3.3	1.3	2.6	-
Analog / CANopen redundant	0.7	1.8	5.2	2.5	6.4	-	1.1	2.0	4.6	2.3	4.5	-
SSI / Incremental	0.4	0.7	2.2	-	-	-	-	-	-	-	-	-

## Connector System M12

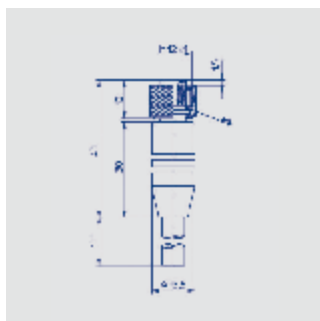

Pin assignment  
1 = Brown  
2 = White  
3 = Blue  
4 = Black



**M12x1 mating female connector, 4-pin, straight, A-coded, with molded cable, shielded, IP67, open ended**

Connector housing	Plastic PA	
Cable sheath	PUR; Ø = max. 6 mm, -25 °C...+80 °C (moved) -50 °C...+80 °C (fixed)	
Wires	PP, 0,34 mm <sup>2</sup>	
<b>Length</b>	<b>Type</b>	<b>P/N</b>
2 m	EEM 33-32	005600
5 m	EEM 33-62	005609
10 m	EEM 33-97	005650

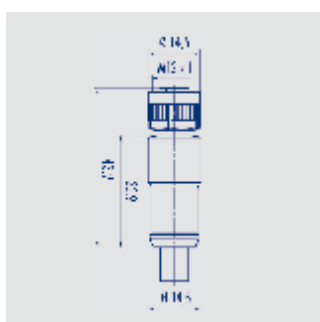

Pin assignment  
1 = Brown  
2 = White  
3 = Blue  
4 = Black

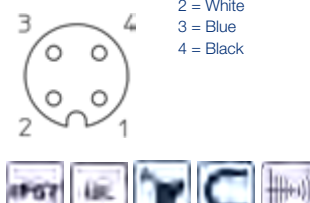

**M12x1 mating female connector, 4-pin, straight, A-coded, with molded cable, not shielded, IP67, open ended**

Connector housing	Plastic PA	
Cable sheath	PUR; Ø = max. 6 mm, -40 °C...+85 °C	
Wires	PP, 0,34 mm <sup>2</sup>	
<b>Length</b>	<b>Type</b>	<b>P/N</b>
2 m	EEM 33-35	056135
5 m	EEM 33-36	056136
10 m	EEM 33-37	056137

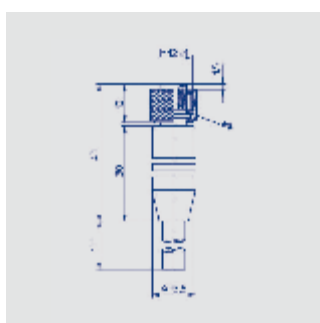

Pin assignment  
1 = White  
2 = Brown  
3 = Green  
4 = Yellow  
5 = grau  
6 = rosa  
7 = Blue  
8 = Red



**M12x1 mating female connector, 8-pin, straight, A-coded, with molded cable, shielded, IP67, open ended**

Connector housing	Plastic PA	
Cable sheath	PUR; Ø = max. 8 mm, -25 °C...+80 °C (moved) -50 °C...+80 °C (fixed)	
Wires	PP, 0,25 mm <sup>2</sup>	
<b>Length</b>	<b>Type</b>	<b>P/N</b>
2 m	EEM 33-86	005629
5 m	EEM 33-90	005635
10 m	EEM 33-92	005637

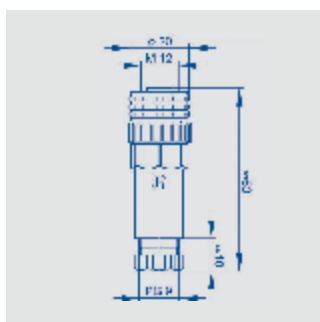

Pin assignment



**M12x1 mating female connector, 4-pin, straight, A-coded, with coupling nut, screw termination, IP67, not shielded**

Connector housing	Plastic PBT -25 °C...+90 °C	
For wire gauge	6...8mm, max. 0,75 mm <sup>2</sup>	
Type EEM 33-88, P/N 005633		

## Connector System M12

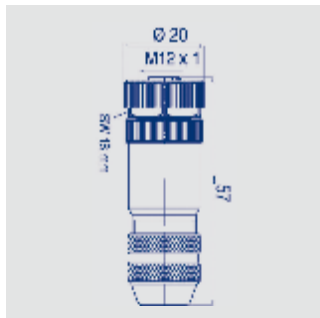

Pin assignment



**M12x1 mating female connector, 5-pin, straight, A-coded, with coupling nut, screw termination, IP67, shieldable, CAN bus**

Connector housing	Metal -40 °C...+85 °C
For wire gauge	6...8 mm, max. 0.75 mm <sup>2</sup>
Type	EEM 33-73, P/N 005645

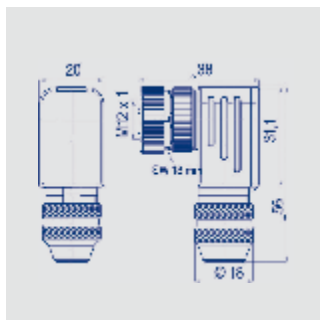

Pin assignment



**M12x1 mating female connector, 5-pin, angled, A-coded, with coupling nut, screw termination, IP67, shieldable, CAN bus**

Connector housing	Metal -40 °C...+85 °C
For wire gauge	6...8 mm, max. 0.75 mm <sup>2</sup>
Type	EEM 33-75, P/N 005646

It is possible to turn and fix the contact carrier in 90° positions.

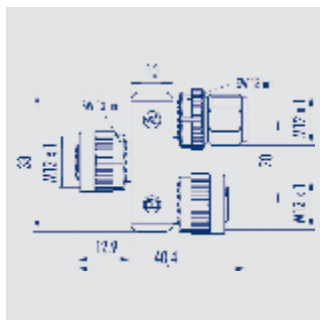

Pin assignment

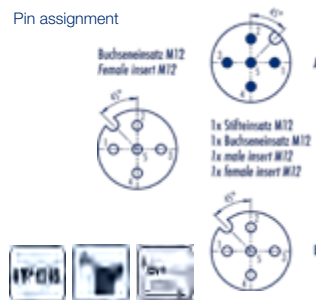

**M12x1 splitter / T-connector, 5-pin, A-coded, IP68, 1:1 connection, female - male - female, CAN-Bus**

Connector housing	PUR
Operating temperature	-25 °C... +85 °C
Type	EEM 33-45, P/N 056145



## Connector System M12

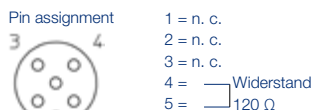
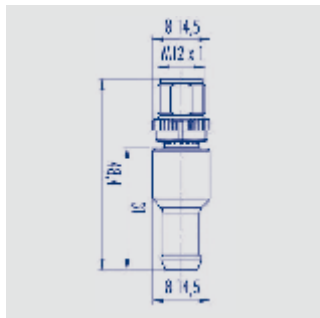

**M12x1 terminating resistor, 5-pin, A-coded, IP67, 120 Ω resistance, CAN-Bus**

Connector housing PUR

Operating temperature -25 °C... +85 °C

Type EEM 33-47, P/N 056147

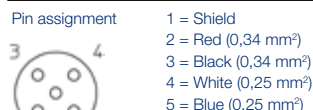
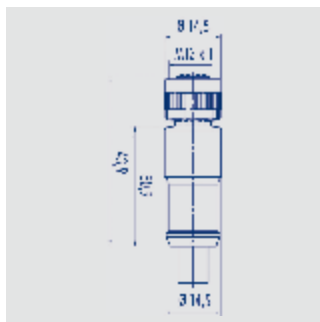

**M12x1 mating female connector, 5-pin, straight, A-coded, with molded cable, IP67, shielded, open ended, CAN-Bus**

Connector housing PUR

Cable sheath PUR Ø = max. 7.2 mm, -25 °C...+85 °C (moved)

Wires PP 2x 0.25 mm<sup>2</sup> + 2 x 0.34 mm<sup>2</sup>

Length	Type	P/N
2 m	EEM 33-41	056141
5 m	EEM 33-42	056142
10 m	EEM 33-43	056143

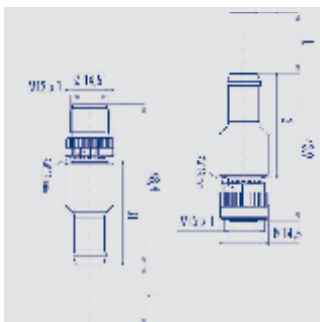

Pin assignment



**M12x1 mating female connector, 5-pin, straight, A-coded, with molded cable, IP68, CAN-Bus**

Connector housing PUR

Cable sheath PUR; Ø 7.2 mm -25 °C... +85 °C (fixed)

Length	Type	P/N
5 m	EEM 33-44	056144



Protection class IP67 DIN EN 60529



Protection class IP68 DIN EN 60529



CAN-bus



Very good Electromagnetic Compatibility (EMC) and shield systems



Very good resistance to oils, coolants und lubricants



UL - approved



Suited for applications in dragchains

**Note:** The protection class is valid only in locked position with its plugs. The application of these products in harsh environments must be checked in particular cases.

## Multifunctional Measuring Device with Display

Series MAP4000

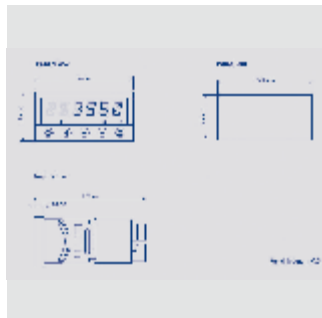

### Special features

- Supply voltage 10...30 VDC, 80...250 V DC or AC
- high accuracy
- direct connection of potentiometric and standardized signals
- adjustable supply voltage for sensors 5... 24 V
- Temperature coefficient 100 ppm/K
- optional RS 232, RS 485, analog output, limited switch

### Ordering specifications

#### Number comparator relays

- 0: none
- 2: 2 relays
- 4: 4 relays

#### Analog output

- 0: no analog output
- 1: analog output present

#### Interface

- 0: ni interface
- 1: RS 232
- 2: RS 485

**M A P - 4 0 1 0 - 0 0 0 - 1 0 1**

Series

#### Supply voltage

- 00: 10...30 V AC/DC
- 10: 80...250 V AC

#### Display colour

- 1: Red

#### Data storage (only with interface)

- 0: not storage
- 1: RTC storage
- 2: FAST storage

#### Adjustable Excitation voltage (5...24 V/Max. 1,2 W)

- 1: Excitation present

## Connecting Options on request

Novotechnik  
Messwertaufnehmer OHG  
Postfach 4220  
73745 Ostfildern (Ruit)  
Horbstraße 12  
73760 Ostfildern (Ruit)  
Telefon +49 711 4489-0  
Telefax +49 711 4489-118  
info@novotechnik.de  
www.novotechnik.de



© 01/2017  
Printed in Germany.



### M12 connector

- Customized lengths
- 3-, 4-, 6- and 8-pole versions
- Protection class IP68
- Ordering codes of standard versions see ordering specifications



### Molex Mini Fit jr.

- Customized length and lead wires
- 3-, 4- and 6-pole versions
- on request



### Tyco AMP Super Seal

- Pin- and bushing housing
- Customized lengths
- 3-, 4- and 6-pole versions
- Protection class IP67
- on request



### Molex Mini Fit

- Customized length and lead wires
- 3-, 4-, 6- and 8-pole versions
- on request



### Deutsch DTM 04

- Pin- and bushing housing
- Customized lengths
- 3-, 4- and 6-pole versions
- Protection class IP67
- on request



### ITT Cannon Sure Seal connector

- customized lengths
- 3-, 4- and 6-pole versions
- protection class IP67
- on request

The specifications contained in our datasheets are intended solely for informational purposes. The documented specification values are based on ideal operational and environmental conditions and can vary significantly depending on the actual customer application. Using our products at or close to one or more of the specified performance ranges can lead to limitations regarding other performance parameters. It is therefore necessary that the end user verifies relevant performance parameters in the intended application. We reserve the right to change product specifications without notice.